

## Yb:YAG-3070

YBYG-PL0004-W2N

### SINGLE CRYSTAL FIBER AMPLIFIER

Single Crystal Fiber (SCF) amplifiers are the best solution to amplify short pulse lasers in a MOPA configuration since they do not suffer from the strongly aberrant thermal lensing effect that degrades the beam in bulk crystal amplifiers. Fibercryst pioneered the SCF technology and developed the Taranis module benefiting from a unique, patented, cooling solution for high power pumping. Taranis module is an industrial component with no adjustments; the only requirements are proper alignment and focusing of the seedlaser.



A Taranis module can amplify a pulsed seed laser from a few kHz to several tens of MHz, or a seed laser from tens of nanoseconds down to a few hundred of femtoseconds with seed powers ranging from a few hundred of mWatts up to tens of Watts.

Taranis modules are available with Yb:YAG (Ytterbium) or Nd:YAG (Neodymium) material.

### Yb:YAG Water cooled module

#### CRYSTAL DIMENSION

- Length : 30 +/- 1 mm
- Typical Diameter : 1 mm +/- 5%
- Typical doping rate: 1 % at. +/- 0.1%

#### WATER-COOLED SYSTEM

- Typical heat transfer coefficient fiber/metallic plate  $H=5W/cm^2.K$
- Dimensioned for up to 200 W pumping
- Copper water box with protective Ni layer

Water cooling should be operated under 5 bars of pressure and between 3 to 4 l/min at 20°C

Operating temperature: +15°C to +35°C (no condensing water)

Storage temperature: +15°C to +35°C (no condensing water)

## DIMENSIONS

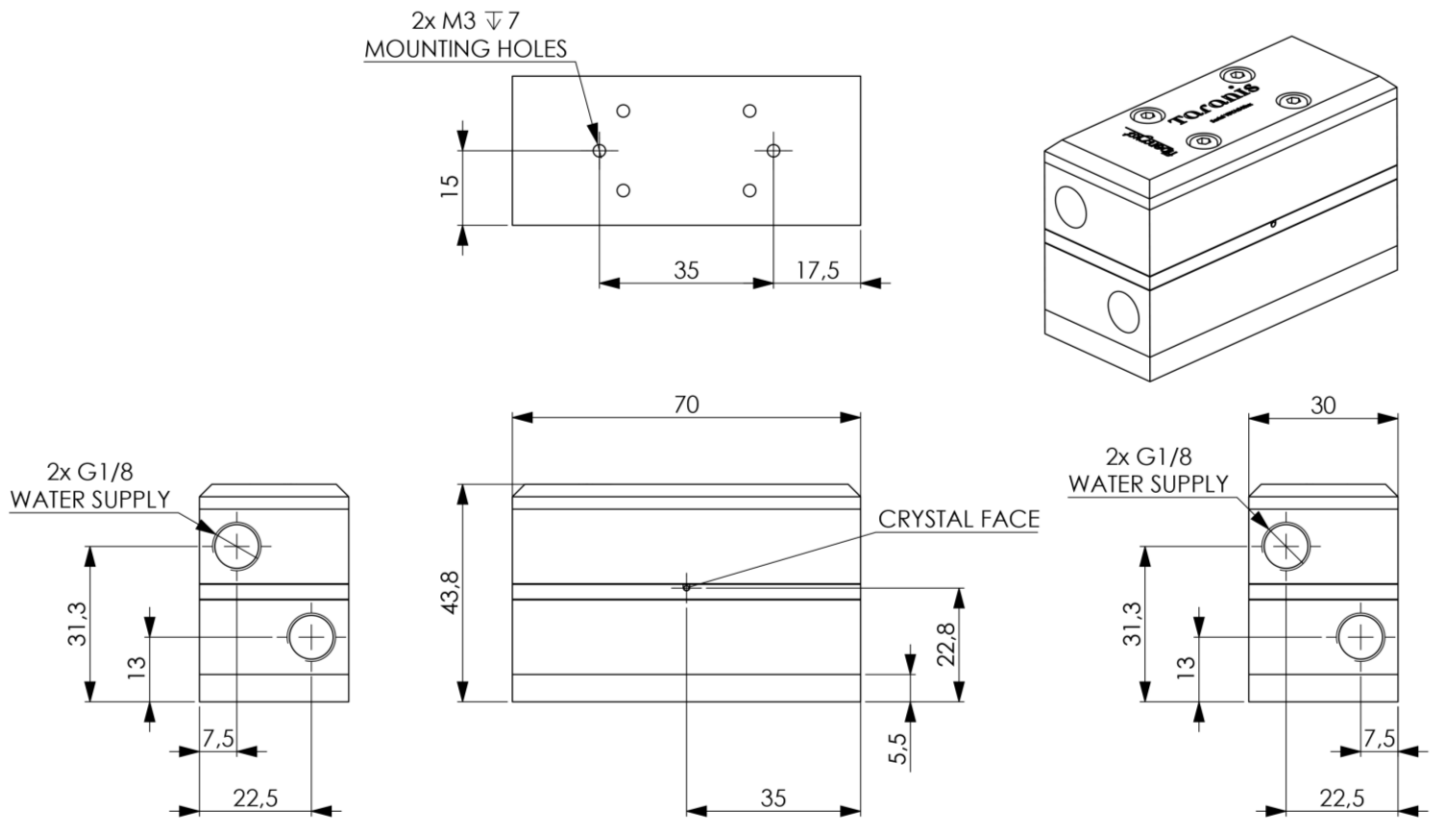

## OPTICAL SPECIFICATIONS

Typical transmission	>95% at 1 $\mu\text{m}$ (see note 1 and note 4)
Depolarization losses	< 2% (see note 1)
Guiding efficiency	> 80% at 1 $\mu\text{m}$ (see note 1)
Coating	AR/AR 940 nm and 1030 nm.
Clear aperture diameter	800 $\mu\text{m}$
Max energy density	10 J/cm <sup>2</sup> at 1 ns pulse duration
Pump wavelength	940 nm
Max pump power	200 W (see note 2)
Max input pulse duration	Continuous wave
Min output pulse duration	400 fs (see note 3)

(1) Experimental conditions upon request. The transmission value takes into account the reabsorption effect at 1  $\mu\text{m}$  without pumping.

(2) Above 200 W of pump power, contact FIBERCRYST for specific recommendation.

(3) This value can be achieved after compression of amplified ultra-short pulses. It is limited by the bandwidth of the crystal.

(4) For optimum performances the center wavelength should be at 1030 nm + or - 0,3 nm and the full width at half maximum (FWHM) lower than 2.5 nm.